

Package leaflet: Information for the user

Apidra® SoloStar®

**100 Units/ml
solution for injection
in a pre-filled pen
insulin glulisine**



Is this leaflet hard to see or read? Phone 0800 035 2525 for help.

sanofi

Read carefully all of this leaflet including the Instructions for Use of Apidra SoloStar, pre-filled pen, before using this medicine because it contains important information for you.

- Keep this leaflet. You may need to read it again.
- If you have any further questions, ask your doctor, pharmacist or nurse.
- This medicine has been prescribed for you only. Do not pass it on to others. It may harm them, even if their signs of illness are the same as yours.
- If you get any side effects, talk to your doctor, pharmacist or nurse. This includes any possible side effects not listed in this leaflet. See section 4.



<MAT>-865203

What is in this leaflet

1. What Apidra is and what it is used for
2. What you need to know before you use Apidra
3. How to use Apidra
4. Possible side effects
5. How to store Apidra
6. Contents of the pack and other information

1. What Apidra is and what it is used for

Apidra is an antidiabetic agent, used to reduce high blood sugar in patients with diabetes mellitus; it may be given to adults, adolescents and children, 6 years of age and older. Diabetes mellitus is a disease where your body does not produce enough insulin to control the level of blood sugar. It is made by biotechnology. It has a rapid onset within 10-20 minutes and a short duration, about 4 hours.

2. What you need to know before you use Apidra

Do not use Apidra

- If you are allergic to insulin glulisine or any of the other ingredients of this medicine (listed in section 6).
- If your blood sugar is too low (hypoglycaemia), follow the guidance for hypoglycaemia (see box at the end of this leaflet).

Warnings and precautions

Apidra in a pre-filled pen is only suitable for injecting just under the skin (see also section 3). Speak to your doctor if you need to inject your insulin by another method.

Talk to your doctor, pharmacist or nurse before using Apidra. Follow closely the instructions for dose, monitoring (blood tests), diet and physical activity (physical work and exercise) as discussed with your doctor.

Special patient groups

If you have liver or kidney problems, speak to your doctor as you may need a lower dose.

There is insufficient clinical information on the use of Apidra in children younger than the age of 6 years.

Skin changes at the injection site

The injection site should be rotated to prevent skin changes such as lumps under the skin. The insulin may not work very well if you inject into a lumpy area (see How to use Apidra). Contact your doctor if you are currently injecting into a lumpy area before you start injecting in a different area. Your doctor may tell you to check your blood sugar more closely, and to adjust your insulin or your other antidiabetic medications dose.

Travel

- Before travelling consult your doctor. You may need to talk about
- the availability of your insulin in the country you are visiting,
 - supplies of insulin, needles, etc,
 - correct storage of your insulin while travelling,
 - timing of meals and insulin administration while travelling,
 - the possible effects of changing to different time zones,
 - possible new health risks in the countries to be visited,
 - what you should do in emergency situations when you feel unwell or become ill.

Illnesses and injuries

In the following situations, the management of your diabetes may require extra care:

- If you are ill or have a major injury then your blood sugar level may increase (hyperglycaemia).
 - If you are not eating enough your blood sugar level may become too low (hypoglycaemia).
- In most cases you will need a doctor. **Make sure that you contact a doctor early.**

If you have type 1 diabetes (insulin dependent diabetes mellitus), do not stop your insulin and continue to get enough carbohydrates. Always tell people who are caring for you or treating you that you require insulin.

Some patients with long-standing type 2 diabetes mellitus and heart disease or previous stroke who were treated with pioglitazone and insulin experienced the development of heart failure. Inform your doctor as soon as possible if you experience signs of heart failure such as unusual shortness of breath or rapid increase in weight or localised swelling (oedema).

Other medicines and Apidra

Some medicines cause changes in the blood sugar level (decrease, increase or both depending on the situation). In each case, it may be necessary to adjust your insulin dose to avoid blood sugar levels that are either too low or too high. Be careful when you start or stop taking another medicine. Tell your doctor or pharmacist if you are taking, have recently taken or might take any other medicines. Before taking a medicine ask your doctor if it can affect your blood sugar level and what action, if any, you need to take.

Medicines that may cause your blood sugar level to fall (hypoglycaemia) include:

- all other medicines to treat diabetes,
- angiotensin converting enzyme (ACE) inhibitors

- (used to treat certain heart conditions or high blood pressure),
- disopyramide (used to treat certain heart conditions),
- fluoxetine (used to treat depression),
- fibrates (used to lower high levels of blood lipids),
- monoamine oxidase (MAO) inhibitors (used to treat depression),
- pentoxifylline, propoxyphene, salicylates (such as aspirin, used to relieve pain and lower fever),
- sulphonamide antibiotics.

Medicines that may cause your blood sugar level to rise (hyperglycaemia) include:

- corticosteroids (such as “cortisone” used to treat inflammation),
- danazol (medicine acting on ovulation),
- diazoxide (used to treat high blood pressure),
- diuretics (used to treat high blood pressure or excessive fluid retention),
- glucagon (pancreas hormone used to treat severe hypoglycaemia),
- isoniazid (used to treat tuberculosis),
- oestrogens and progestogens (such as in the contraceptive pill used for birth control),
- phenothiazine derivatives (used to treat psychiatric disorders),
- somatropin (growth hormone),
- sympathomimetic medicines (such as epinephrine [adrenaline], salbutamol, terbutaline used to treat asthma),
- thyroid hormones (used to treat thyroid gland disorders),
- protease inhibitors (used to treat HIV),
- atypical antipsychotic medicines (such as olanzapine and clozapine).

Your blood sugar level may either rise or fall if you take:

- beta-blockers (used to treat high blood pressure),
 - clonidine (used to treat high blood pressure),
 - lithium salts (used to treat psychiatric disorders).
- Pentamidine (used to treat some infections caused by parasites) may cause hypoglycaemia which may sometimes be followed by hyperglycaemia. Beta-blockers like other sympatholytic medicines (such as clonidine, guanethidine and reserpine) may weaken or suppress entirely the first warning symptoms which help you to recognise a hypoglycaemia. If you are not sure whether you are taking one of those medicines ask your doctor or pharmacist.

Apidra with alcohol

Your blood sugar levels may either rise or fall if you drink alcohol.

Pregnancy and breast-feeding

If you are pregnant or breast-feeding, think you may be pregnant or are planning to have a baby, ask your doctor or pharmacist for advice before taking this medicine. Inform your doctor if you are planning to become pregnant, or if you are already pregnant. Your insulin dose may need to be changed during pregnancy and after giving birth. Careful control of your diabetes, and prevention of hypoglycaemia, is important for the health of your baby. There are no or limited data on the use of Apidra in pregnant women.

If you are breast-feeding consult your doctor as you may require adjustments in your insulin doses and your diet.

Driving and using machines

Your ability to concentrate or react may be reduced if:

- you have hypoglycaemia (low blood sugar levels),
- you have hyperglycaemia (high blood sugar levels).

Keep this possible problem in mind in all situations where you might put yourself and others at risk (such as driving a car or using machines). You should contact your doctor for advice on driving if:

- you have frequent episodes of hypoglycaemia,
- the first warning symptoms which help you to recognise hypoglycaemia are reduced or absent.

Important information about some of the ingredients of Apidra

This medicine contains less than 1 mmol (23 mg) sodium per dose, i.e. it is essentially ‘sodium-free’.

Apidra contains metacresol

Apidra contains metacresol, which may cause allergic reactions.

3. How to use Apidra

Dose

Always use this medicine exactly as your doctor has told you. Check with your doctor or pharmacist if you are not sure. Based on your life-style and the results of your blood sugar (glucose) tests and your previous insulin usage, your doctor will determine how much Apidra you will need.

Apidra is a short-acting insulin. Your doctor may tell you to use it in combination with an intermediate, long acting insulin, a basal insulin or with tablets used to treat high blood sugar levels. If you switch from another insulin to insulin glulisine, your dosage may have to be adjusted by your doctor.

Many factors may influence your blood sugar level. You should know these factors so that you are able to react correctly to changes in your blood sugar level and to prevent it from becoming too high or too low. See the box at the end of this leaflet for further information.

Method of administration

Apidra is injected under the skin (subcutaneously). Your doctor will show you in which area of the skin you should inject Apidra. Apidra can be injected in the abdominal wall, the thigh or upper arm or by continuous infusion in the abdominal wall. The effect will be slightly quicker if the insulin is injected into your abdomen. As for all insulins, injection sites and infusion sites within an injection area (abdomen, thigh or upper arm) must be rotated from one injection to the next.

Frequency of administration

Apidra should be taken shortly (0-15 minutes) before or soon after meals.

Instructions for proper use

How to handle SoloStar

SoloStar is a pre-filled disposable pen containing insulin glulisine. Apidra in a pre-filled pen is only suitable for injecting just under the skin. Speak to your doctor if you need to inject your insulin by another method.

Read carefully the “SoloStar Instructions for use” included in this package leaflet. You must use the pen as described in these Instructions for use.

To prevent the possible transmission of disease, each pen must be used by one patient only. Before use always attach a new needle, and perform a safety test. Only use needles that are compatible for use with SoloStar (see “SoloStar Instructions for use”). Look at the cartridge sealed in the disposable pen injector before you use it. Only use it if the solution is clear, colourless and has no visible particles in it.

Do not shake or mix it before use. Always use a new pen if you notice that your blood sugar control is unexpectedly getting worse. If you think you may have a problem with SoloStar, please consult your Health Care Professional.

If you use more Apidra than you should

- If you **have injected too much Apidra**, your blood sugar level may become too low (hypoglycaemia). Check your blood sugar frequently. In general, to prevent hypoglycaemia you must eat more food and monitor your blood sugar. For information on the treatment of hypoglycaemia, see box at the end of this leaflet.

If you forget to use Apidra

- If you **have missed a dose of Apidra** or if you **have not injected enough insulin**, your blood sugar level may become too high (hyperglycaemia). Check your blood sugar frequently. For information on the treatment of hyperglycaemia, see box at the end of this leaflet.
- Do not take a double dose to make up for a forgotten dose.

If you stop using Apidra

This could lead to severe hyperglycaemia (very high blood sugar) and ketoacidosis (build-up of acid in the blood because the body is breaking down fat instead of sugar). Do not stop Apidra without speaking to a doctor, who will tell you what needs to be done.

If you have any further questions on the use of this medicine, ask your doctor, pharmacist or nurse.

Insulin Mix-ups

You must always check the insulin label before each injection to avoid mix-ups between Apidra and other insulins.

4. Possible side effects

Like all medicines, this medicine can cause side effects, although not everybody gets them.

Serious side effects

Hypoglycaemia (low blood sugar) can be very serious. Hypoglycaemia is a very commonly reported side effect (may affect more than 1 in 10 people).

Hypoglycaemia (low blood sugar) means that there is not enough sugar in the blood.

If your blood sugar level falls too much you may become unconscious. Serious hypoglycaemia may cause brain damage and may be life-threatening. If you have symptoms of low blood sugar, take actions to increase your blood sugar level **immediately**. See the box at the end of this leaflet for important further information about hypoglycaemia and its treatment.

If you experience the following symptoms, contact your doctor immediately: Systemic allergic reactions are side effects reported uncommonly (may affect up to 1 in 100 people).

Generalised allergy to insulin: Associated symptoms may include large-scale skin reactions (rash and itching all over the body), severe swelling of skin or mucous membranes (angioedema), shortness of breath, a fall in blood pressure with rapid heart beat and sweating. These could be symptoms of severe cases of **generalised allergy to insulin, including anaphylactic reaction, which may be life-threatening.**



<MAT>-865203

Hyperglycaemia (high blood sugar) means that there is too much sugar in the blood.

The frequency of hyperglycaemia cannot be estimated. If your blood sugar level is too high, this tells you that you may need more insulin than you have injected. This can be serious if your blood glucose level becomes very high. For more information on signs and symptoms of hyperglycaemia refer to the box at the end of this leaflet.

Other side effects

Tell your doctor, pharmacist or nurse if you notice any of the following side effects:

- Skin changes at the injection site: If you inject insulin too often at the same place, the fatty tissue may either shrink (lipoatrophy) or thicken (lipohypertrophy) (*may affect up to 1 in 1,000 people*). Lumps under the skin may also be caused by build-up of a protein called amyloid (cutaneous amyloidosis; how often this occurs is not known). The insulin may not work very well if you inject into a lumpy area. Change the injection site with each injection to help prevent these skin changes.

Common reported side effects (may affect up to 1 in 10 people)

- Skin and allergic reactions at the injection site Reactions at the injection site may occur (such as reddening, unusually intense pain on injection, itching, hives, swelling or inflammation). They can also spread around the injection site. Most minor reactions to insulins usually resolve in a few days to a few weeks.

Side effects where the frequency cannot be estimated from the available data

• Eye reactions

A marked change (improvement or worsening) in your blood sugar control can disturb your vision temporarily. If you have proliferative retinopathy (an eye disease related to diabetes) severe hypoglycaemic attacks may cause temporary loss of vision.

Reporting of side effects

If you get any side effects, talk to your doctor, pharmacist or nurse. This includes any possible side effects not listed in this leaflet.

You can also report side effects directly via the Yellow Card Scheme at:

www.mhra.gov.uk/yellowcard or search for MHRA Yellow Card in the Google Play or Apple App Store.

By reporting side effects you can help provide more information on the safety of this medicine.

5. How to store Apidra

Keep this medicine out of the sight and reach of children. Do not use this medicine after the expiry date, which is stated on the carton and on the label of the pen after “EXP”. The expiry date refers to the last day of that month.

Not in-use pens

Store in a refrigerator (2°C-8°C). Do not freeze. Do not put SoloStar next to the freezer compartment or a freezer pack. Keep the pre-filled pen in the outer carton in order to protect from light.

In-use pens

Pre-filled pens in use (or carried as a spare) may be stored for a maximum of 4 weeks below 25°C and away from direct heat or direct light. The pen in use must not be stored in a refrigerator. Do not use it after this time period. Do not use this medicine if it does not appear clear and colourless. Do not throw away any medicines via wastewater or household waste. Ask your pharmacist how to throw away medicines you no longer use. These measures will help protect the environment.

6. Contents of the pack and other information

What Apidra contains

- The active substance is insulin glulisine. Each ml of the solution contains 100Units of insulin glulisine (equivalent to 3.49 mg).
- The other ingredients are: metacresol (see section 2 under “Apidra contains metacresol”), sodium chloride (see section 2 under “Important information about some of the ingredients of Apidra”), trometamol, polysorbate 20, concentrated hydrochloric acid, sodium hydroxide, water for injections

What Apidra looks like and contents of the pack

Apidra SoloStar 100Units/ml solution for injection in a pre-filled pen. It is a clear, colourless, aqueous solution with no particles visible. Each pen contains 3 ml solution, equivalent to 300Units. Packs of 1, 3, 4, 5, 6, 8, 9 and 10 prefilled pens are available. Not all pack sizes may be marketed.

Marketing Authorisation Holder and Manufacturer

Marketing Authorisation Holder
Sanofi
410 Thames Valley Park Drive
Reading
Berkshire
RG6 1PT
UK
Tel: 0800 035 2525
Email: uk-medicalinformation@sanofi.com

Manufacturer

Sanofi-Aventis Deutschland GmbH
Industriepark Höchst, D-65926 Frankfurt
Germany

This leaflet does not contain all the information about your medicine. If you have any questions or are not sure about anything, ask your doctor or pharmacist.

This leaflet was last revised in October 2022

Apidra® SoloStar® solution for injection in a pre filled-pen INSTRUCTIONS FOR USE

HYPERGLYCAEMIA AND HYPOGLYCAEMIA
Always carry some sugar (at least 20 grams) with you.
Carry some information with you to show you are a person with diabetes.

HYPERGLYCAEMIA (high blood sugar levels)

If your blood sugar is too high (hyperglycaemia), you may not have injected enough insulin.

Why does hyperglycaemia occur?

- Examples include:
- you have not injected your insulin or not injected enough, or if it has become less effective, for example through incorrect storage,
 - you are doing less exercise than usual, you are under stress (emotional distress, excitement), or you have an injury, operation, infection or fever,
 - you are taking or have taken certain other medicines (see section 2, "Other medicines and Apidra").

Warning symptoms of hyperglycaemia

Thirst, increased need to urinate, tiredness, dry skin, reddening of the face, loss of appetite, low blood pressure, fast heart beat and glucose and ketone bodies in urine. Stomach pain, fast and deep breathing, sleepiness or even loss of consciousness may be signs of a serious condition (ketoacidosis) resulting from lack of insulin.

What should you do if you experience hyperglycaemia?

Test your blood sugar level and your urine for ketones as soon as any of the above symptoms occur. Severe hyperglycaemia or ketoacidosis must always be treated by a doctor, normally in a hospital.

HYPOGLYCAEMIA (low blood sugar levels)

If your blood sugar level falls too much you may become unconscious. Serious hypoglycaemia may cause a heart attack or brain damage and may be life-threatening. You normally should be able to recognise when your blood sugar is falling too much so that you can take the right actions.

Why does hypoglycaemia occur?

- Examples include:
- you inject too much insulin,
 - you miss meals or delay them,
 - you do not eat enough, or eat food containing less carbohydrate than normal (sugar and substances similar to sugar are called carbohydrates; however, artificial sweeteners are NOT carbohydrates),
 - you lose carbohydrates due to vomiting or diarrhoea,
 - you drink alcohol, particularly if you are not eating much,
 - you are doing more exercise than usual or a different type of physical activity,
 - you are recovering from an injury or operation or other stress,
 - you are recovering from an illness or from fever,
 - you are taking or have stopped taking certain other medicines (see section 2, "Other medicines and Apidra").

Hypoglycaemia is also more likely to occur if:

- you have just begun insulin treatment or changed to another insulin preparation,
- your blood sugar levels are almost normal or are unstable,
- you change the area of skin where you inject insulin (for example from the thigh to the upper arm),
- you suffer from severe kidney or liver disease, or some other disease such as hypothyroidism.

Warning symptoms of hypoglycaemia

- In your body
- Examples of symptoms that tell you that your blood sugar level is falling too much or too fast: sweating, clammy skin, anxiety, fast heart beat, high blood pressure, palpitations and irregular heartbeat. These symptoms often develop before the symptoms of a low sugar level in the brain.

- In your brain
- Examples of symptoms that indicate a low sugar level in the brain: headaches, intense hunger, nausea, vomiting, tiredness, sleepiness, sleep disturbances, restlessness, aggressive behaviour, lapses in concentration, impaired reactions, depression, confusion, speech disturbances (sometimes total loss of speech), visual disorders, trembling, paralysis, tingling sensations (paraesthesia), numbness and tingling sensations in the area of the mouth, dizziness, loss of self-control, inability to look after yourself, convulsions and loss of consciousness.

The first symptoms which alert you to hypoglycaemia ("warning symptoms") may change, be weaker or may be missing altogether if:

- you are elderly,
- you have had diabetes for a long time,
- you suffer from a certain type of nervous disease (diabetic autonomic neuropathy),
- you have recently suffered hypoglycaemia (for example the day before) or if it develops slowly,
- you have almost normal or, at least, greatly improved blood sugar levels,
- you are taking or have taken certain other medicines (see section 2, "Other medicines and Apidra").

In such a case, you may develop severe hypoglycaemia (and even faint) before you are aware of the problem. Be familiar with your warning symptoms. If necessary, more frequent blood sugar testing can help to identify mild hypoglycaemic episodes that may otherwise be overlooked. If you are not confident about recognising your warning symptoms, avoid situations (such as driving a car) in which you or others would be put at risk by hypoglycaemia.

What should you do if you experience hypoglycaemia?

1. Do not inject insulin. Immediately take about 10 to 20g sugar, such as glucose, sugar cubes or a sugar-sweetened beverage. Caution: Artificial sweeteners and foods with artificial sweeteners (such as diet drinks) are of no help in treating hypoglycaemia.
2. Then eat something that has a long-acting effect in raising your blood sugar (such as bread or pasta). Your doctor or nurse should have discussed this with you previously.
3. If the hypoglycaemia comes back again take another 10 to 20g sugar.
4. Speak to a doctor immediately if you are not able to control the hypoglycaemia or if it recurs.

Tell your relatives, friends and close colleagues the following:

If you are not able to swallow or if you are unconscious, you will require an injection of glucose or glucagon (a medicine which increases blood sugar). These injections are justified even if it is not certain that you have hypoglycaemia.

It is advisable to test your blood sugar immediately after taking glucose to check that you really have hypoglycaemia.

SoloStar is a pre-filled pen for the injection of insulin. Your doctor has decided that SoloStar is appropriate for you based on your ability to handle SoloStar. Talk with your doctor, pharmacist or nurse about proper injection technique before using SoloStar.

Read these instructions carefully before using your SoloStar. If you are not able to use SoloStar or follow all the instructions completely on your own, you must use SoloStar only if you have help from a person who is able to follow the instructions completely. Hold the pen as shown in this leaflet. To ensure that you read the dose correctly, hold the pen horizontally, with the needle on the left and the dosage selector to the right as shown in the illustrations below.

You can set doses from 1 to 80 units in steps of 1 unit. Each pen contains multiple doses.

Keep this leaflet for future reference.

If you have any questions about SoloStar or about diabetes, ask your doctor, pharmacist or nurse or call the local Sanofi number on the front of this leaflet.

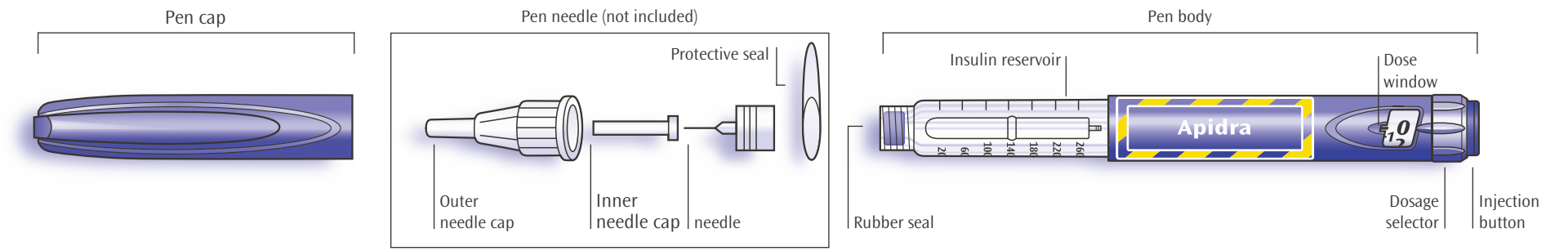

Schematic diagram of the pen

Important information for use of SoloStar:

- Always attach a new needle before each use. Only use needles that are compatible for use with SoloStar.
- Do not select a dose and/or press the injection button without a needle attached.
- Always perform the safety test before each injection (see Step 3).
- This pen is only for your use. Do not share it with anyone else.
- If your injection is given by another person, special caution must be taken by this person to avoid accidental needle injury and transmission of infection.
- Never use SoloStar if it is damaged or if you are not sure that it is working properly.
- Always have a spare SoloStar in case your SoloStar is lost or damaged.

Step 1. Check the insulin

- A. Check the label on your SoloStar to make sure you have the correct insulin. The Apidra SoloStar is blue. It has a dark blue injection button with a raised ring on the top.
- B. Take off the pen cap.
- C. Check the appearance of your insulin. Apidra is a clear insulin. Do not use this SoloStar if the insulin is cloudy, coloured or has particles.

Step 2. Attach the needle

Always use a new sterile needle for each injection. This helps prevent contamination, and potential needle blocks.

- A. Remove the protective seal from a new needle.
- B. Line up the needle with the pen, and keep it straight as you attach it (screw or push on, depending on the needle type).

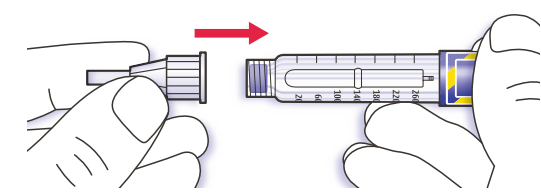

- If the needle is not kept straight while you attach it, it can damage the rubber seal and cause leakage, or break the needle.

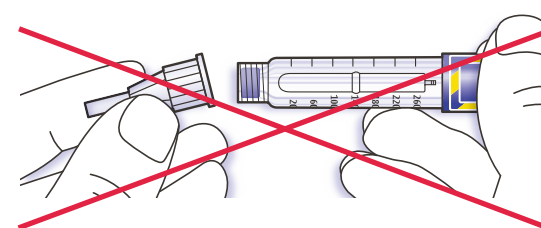

Step 3. Perform a safety test

Always perform the safety test before each injection. This ensures that you get an accurate dose by:

- ensuring that pen and needle work properly
 - removing air bubbles
- A. Select a dose of 2 units by turning the dosage selector.

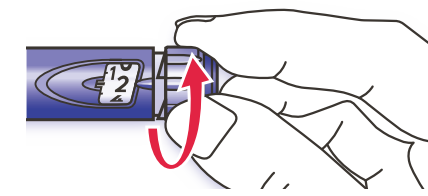

- B. Take off the outer needle cap and keep it to remove the used needle after injection. Take off the inner needle cap and discard it.

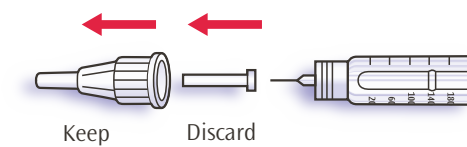

- C. Hold the pen with the needle pointing upwards.
- D. Tap the insulin reservoir so that any air bubbles rise up towards the needle.
- E. Press the injection button all the way in. Check if insulin comes out of the needle tip.

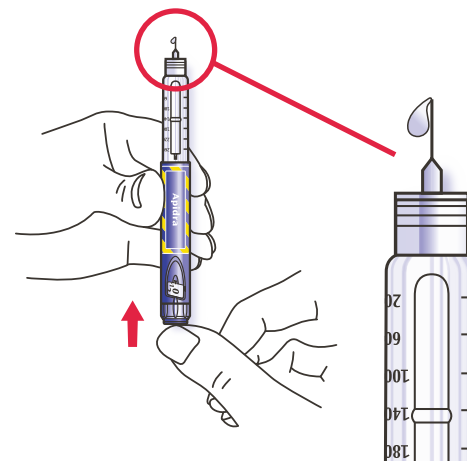

- You may have to perform the safety test several times before insulin is seen.
- If no insulin comes out, check for air bubbles and repeat the safety test two more times to remove them.
 - If still no insulin comes out, the needle may be blocked. Change the needle and try again.
 - If no insulin comes out after changing the needle, your SoloStar may be damaged. Do not use this SoloStar.

Step 4. Select the dose

You can set the dose in steps of 1 unit, from a minimum of 1 unit to a maximum of 80 units. If you need a dose greater than 80 units, you should give it as two or more injections.

- A. Check that the dose window shows "0" following the safety test.
- B. Select your required dose (in the example below, the selected dose is 30 units). If you turn past your dose, you can turn back down.

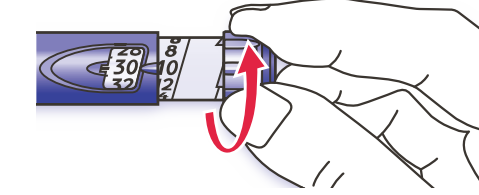

- Do not push the injection button while turning, as insulin will come out.
- You cannot turn the dosage selector past the number of units left in the pen. Do not force the dosage selector to turn. In this case, either you can inject what is remaining in the pen and complete your dose with a new SoloStar or use a new SoloStar for your full dose.

Step 5. Inject the dose

- A. Use the injection method as instructed by your doctor, pharmacist or nurse.
- B. Insert the needle into the skin.

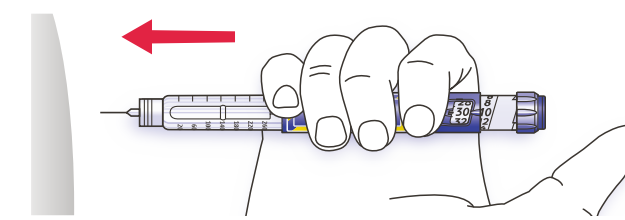

- C. Deliver the dose by pressing the injection button in all the way. The number in the dose window will return to "0" as you inject.

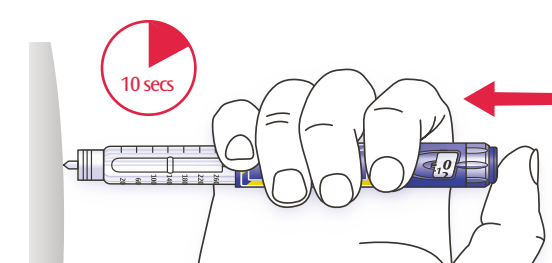

- D. Keep the injection button pressed all the way in. Slowly count to 10 before you withdraw the needle from the skin. This ensures that the full dose will be delivered.

The pen plunger moves with each dose. The plunger will reach the end of the cartridge when the total of 300 units of insulin has been used.

Step 6. Remove and discard the needle

Always remove the needle after each injection and store SoloStar without a needle attached. This helps prevent:

- Contamination and/or infection,
 - Entry of air into the insulin reservoir and leakage of insulin, which can cause inaccurate dosing.
- A. Put the outer needle cap back on the needle, and use it to unscrew the needle from the pen. To reduce the risk of accidental needle injury, never replace the inner needle cap.
 - If your injection is given by another person, or if you are giving an injection to another person, special caution must be taken by this person when removing and disposing of the needle. Follow recommended safety measures for removal and disposal of needles (contact your doctor, pharmacist or nurse) in order to reduce the risk of accidental needle injury and transmission of infectious diseases.
 - B. Dispose of the needle safely, as instructed by your doctor, pharmacist or nurse.
 - C. Always put the pen cap back on the pen, then store the pen until your next injection.

Storage instructions

Please check the reverse (insulin) side of this leaflet for instructions on how to store SoloStar.

If your SoloStar is in cool storage, take it out 1 to 2 hours before you inject to allow it to warm up to room temperature. Cold insulin is more painful to inject.

Discard your used SoloStar as required by your local authorities.

Maintenance

Protect your SoloStar from dust and dirt.

You can clean the outside of your SoloStar by wiping it with a damp cloth.

Do not soak, wash or lubricate the pen as this may damage it.

Your SoloStar is designed to work accurately and safely. It should be handled with care. Avoid situations where SoloStar might be damaged. If you are concerned that your SoloStar may be damaged, use a new one.